

# FMD COMPLIANCE SOLUTIONS

BY ZETES

ΟΔΗΓΙΑ FMD (ΠΡΟΘΕΣΜΙΑ 9 ΦΕΒΡΟΥΑΡΙΟΥ 2025)

Ο ΧΡΟΝΟΣ ΚΥΛΑΕΙ ΑΝΤΙΣΤΡΟΦΑ ΓΙΑ ΤΟΥΣ ΔΙΑΝΟΜΕΙΣ, ΧΟΝΔΡΕΜΠΟΡΟΥΣ ΚΑΙ 3PL  
ΦΑΡΜΑΚΩΝ



# WHO WE ARE

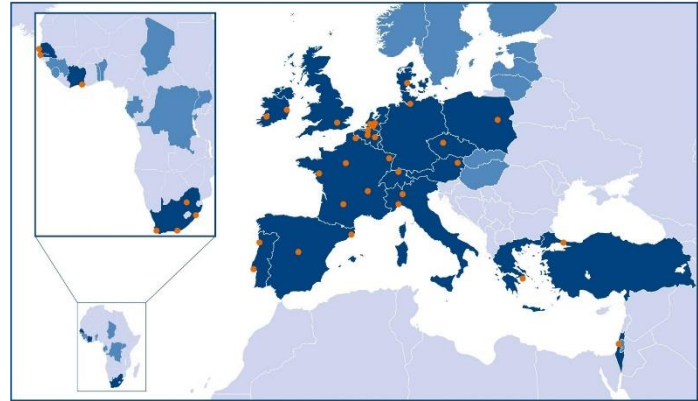

# FMD SERIALISATION OBJECTIVE

PREVENTING COUNTERFEIT OR UNAUTHORISED PRESCRIPTION MEDICINE ENTERING THE SUPPLY CHAIN

Improving Patient Safety

Reducing Fraud

- Serialisation
  - Unique identification of each saleable pack
- Authentication
  - Confirms that pack data agrees with database
  - Enables the pack to be confirmed as dispensed



Maintains the legitimacy of the Pharma supply chain

# PHARMA FMD DIRECTIVE

## ZETES TURNKEY SOLUTION

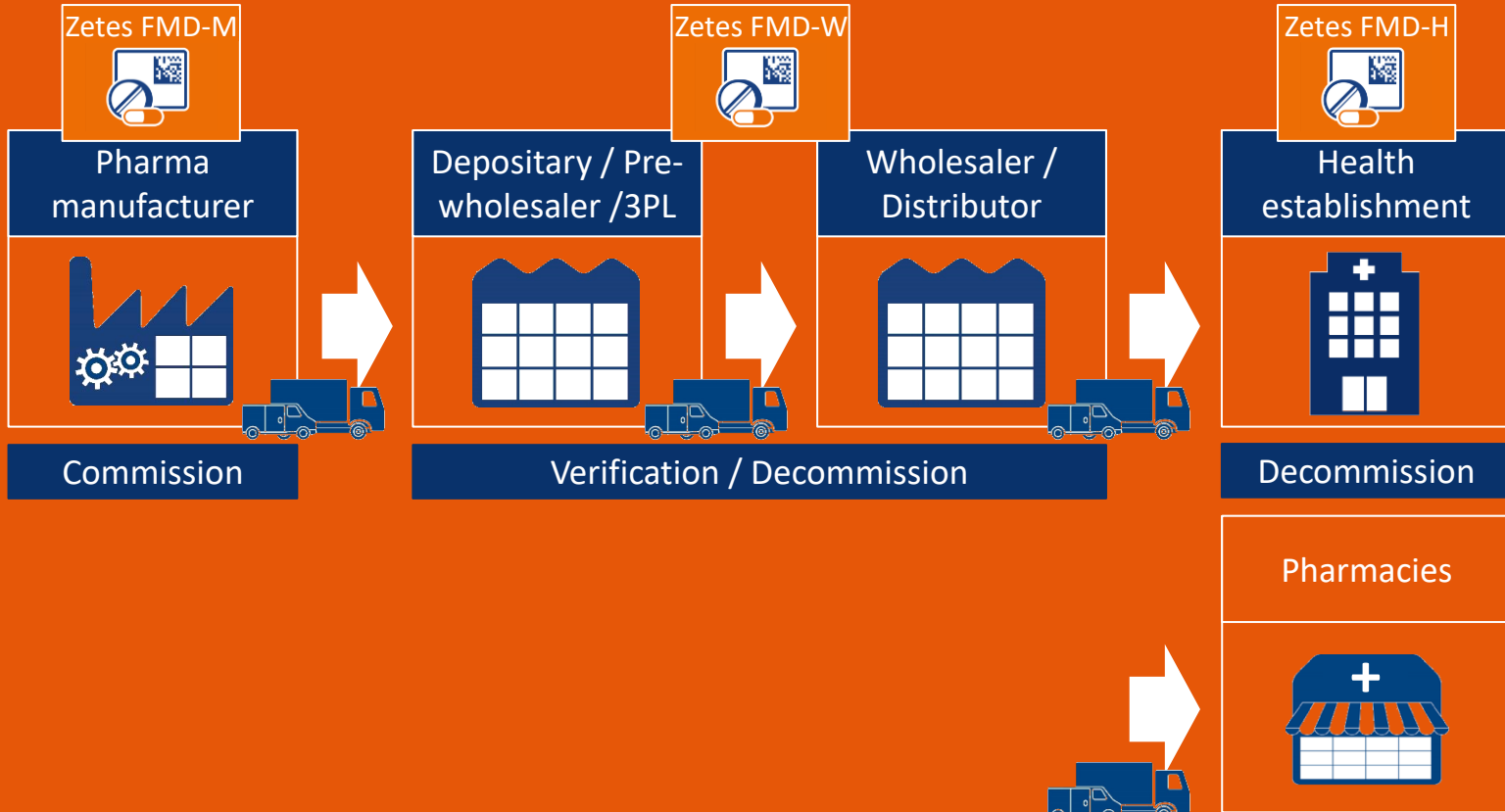

# EUROPEAN MEDICINES VERIFICATION SYSTEM

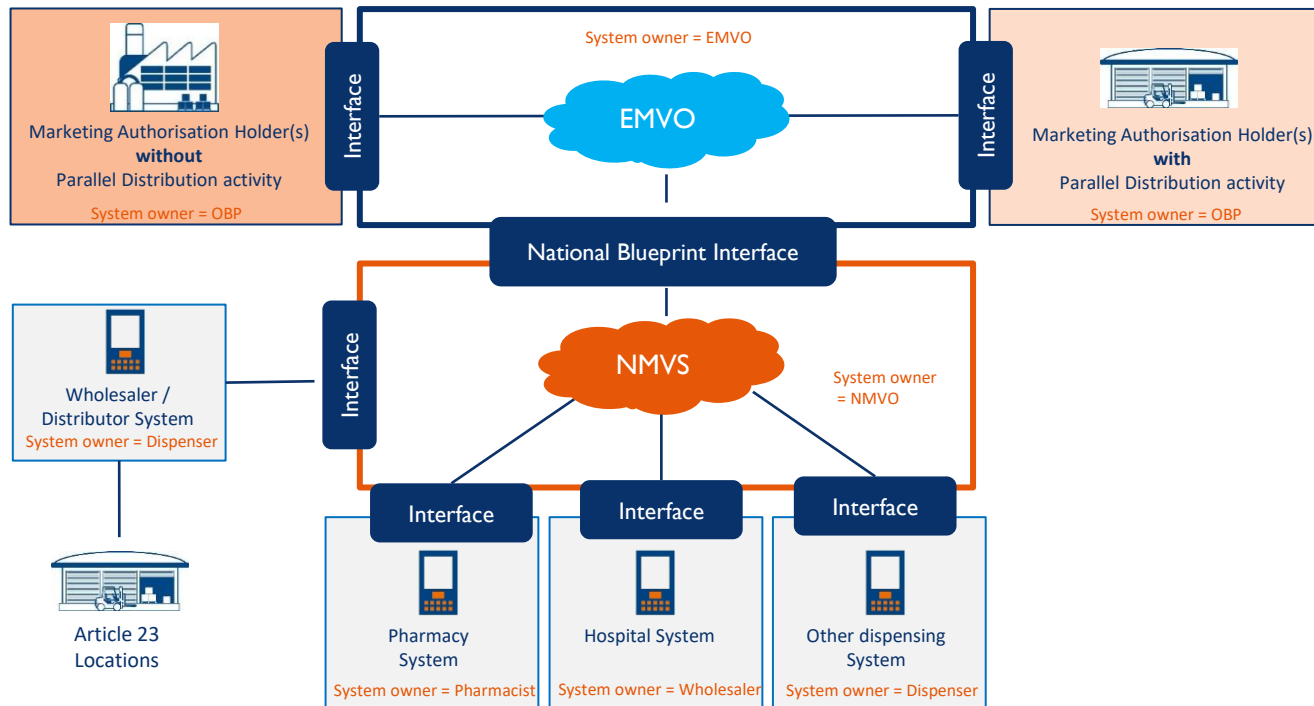

**OBP:** On-boarding Partner  
**NMVS:** National Medicines Verification System  
**NMVO:** National medicines verification Organisation

# RESPONSIBILITIES



Process	Operation	Depository with no MAH	Wholesale Distributor	Health Establish.	Pharmacy
Reception from a Manufacturer (or a CMO that publishes to the EMVS on behalf of a Manufacturer)	Verify or Decom	V	V	D	V
Reception from a Depository	Verify or Decom	V	V	D	V
Reception from a Wholesale Distributor	Verify or Decom	V	V	D	V
Reception from a Pharmacy or a Health Establishment ( <i>return</i> )	Verify or Decom	V	V	D	V
Destruction	Decommission	D	D	D	D
Theft report (Stolen)	Decommission	D	D	D	D
Lock (Quarantine)	Decommission	D	D	D	D
Export to a country outside EU ( <i>article 22</i> )	Decommission	D	D		
Expedition to other organisation (prisons, veterinarians, dentistes, opticiens, police, armée, etc... ( <i>article 23</i> )	Decommission	D	D		
Export to a country inside EU ( <i>Risk Based Verification</i> )	Verify	V	V		
Supply of samples (for authorities)	Decommission	D	D	D	D
Supply of free samples (for healthcare professionals)	Decommission	D	D		
Dispense to patient	Verify or Decom			V	D

Optional (Risk Based)

V or D

Mandatory

V or D



# ZETES FOR PHARMA WHOLESALER & ESTABLISHMENTS

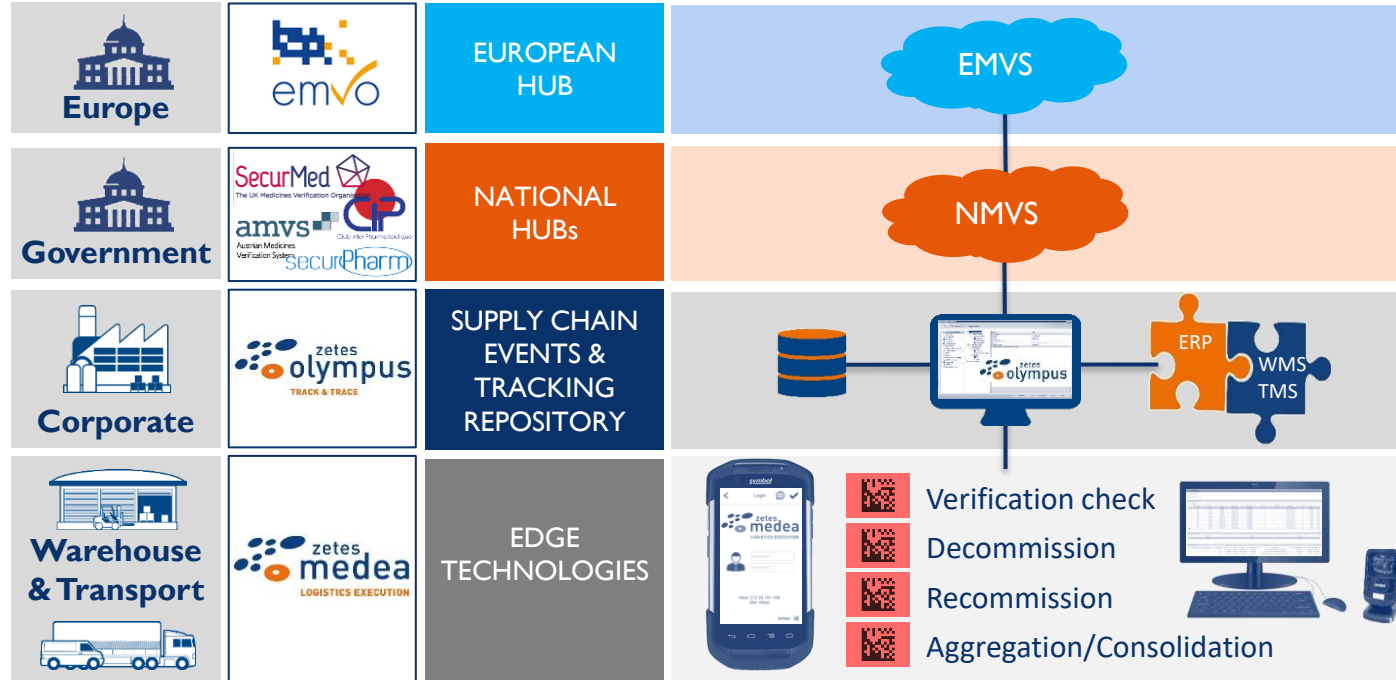



# EDGE TECHNOLOGIES

Warehousing



## FMD-MMS Std Model

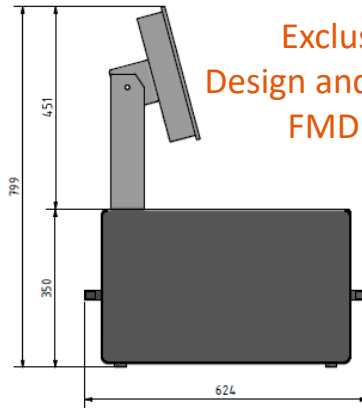
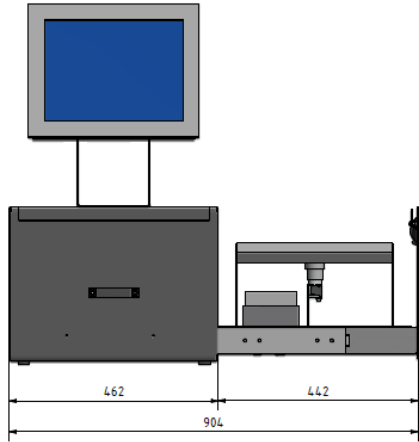

Exclusive Model  
Design and made by Zetes  
FMD dedicated

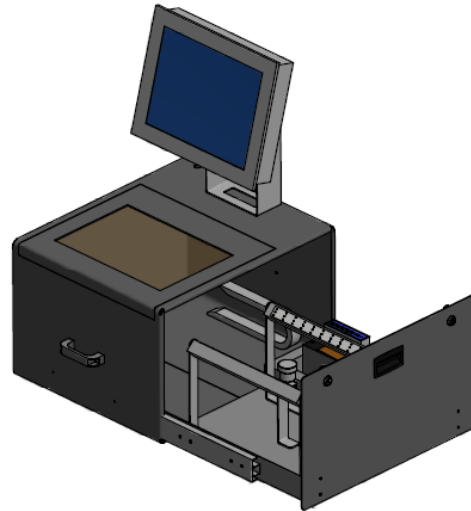
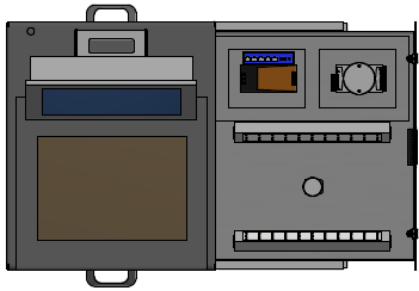

# MULTI-BARCODE SCANNING TABLE

FMD-MMS MODEL,  
TRANSPORTABLE, CAMERA FROM BELOW

- Transportable individual reading station
- Multi-barcode reading using camera module from bottom
- Visual assistance
- Power cabled
- Ethernet & Wifi

# EDGE TECHNOLOGY ENABLERS



# OVER 200 TRACEABILITY CUSTOMERS IN 15 COUNTRIES, INCLUDING...



# ΕΡΩΤΗΣΕΙΣ;

Κατωμελίτης Ανδρέας

Business Development Manager

Andreas.Katomelitis@gr.zetes.com

+30 6943 100 300

Zetes

Λ. Βουλιαγμένης & Γερουλάνου 2,

Αργυρούπολη, Αθήνα

ΤΚ 16452

[www.zetes.com](http://www.zetes.com)

